

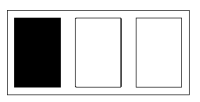

# SECTION 4 SCHEMATIC DIAGRAMS

## 4-1. POWER SCHEMATIC DIAGRAM

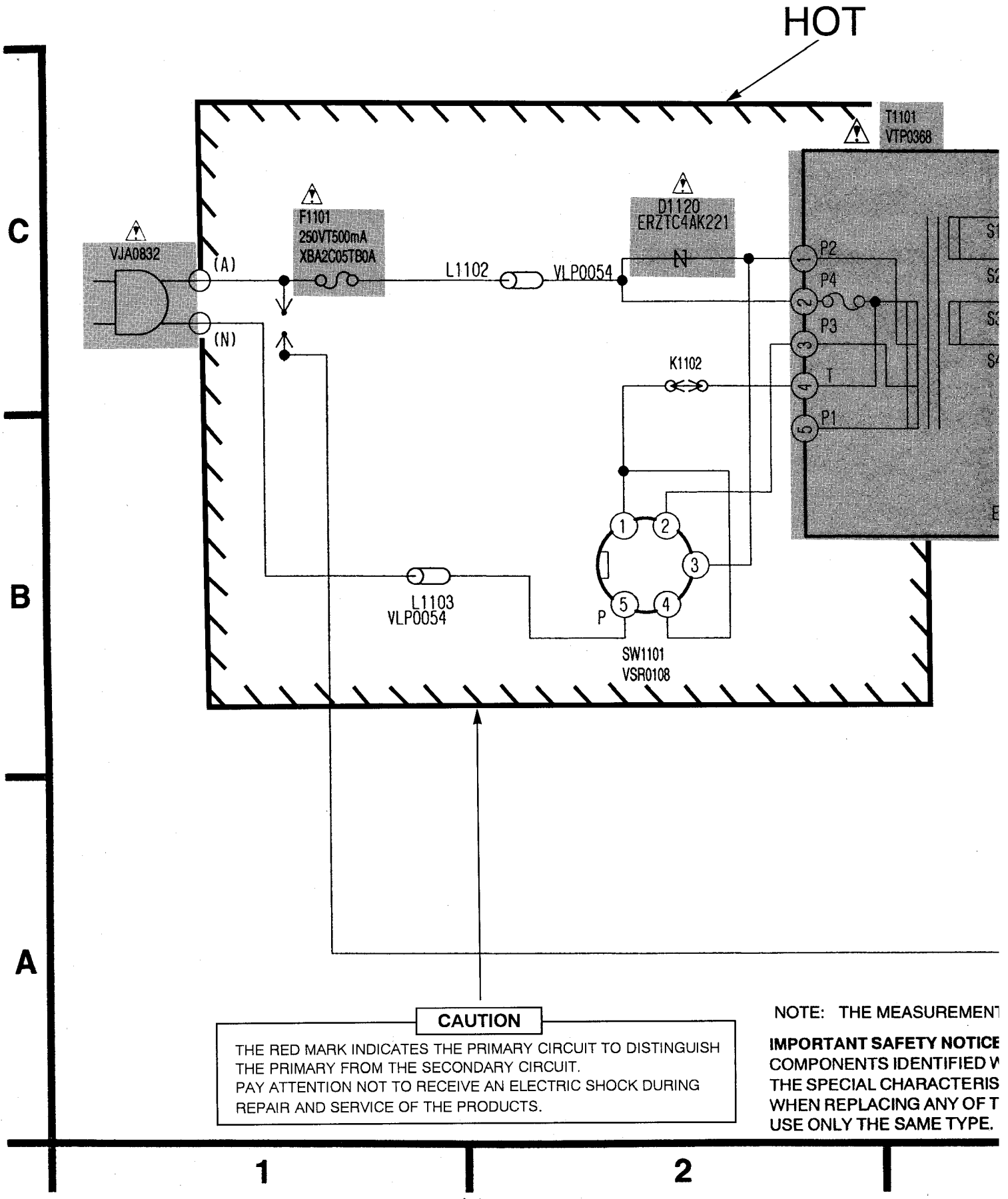

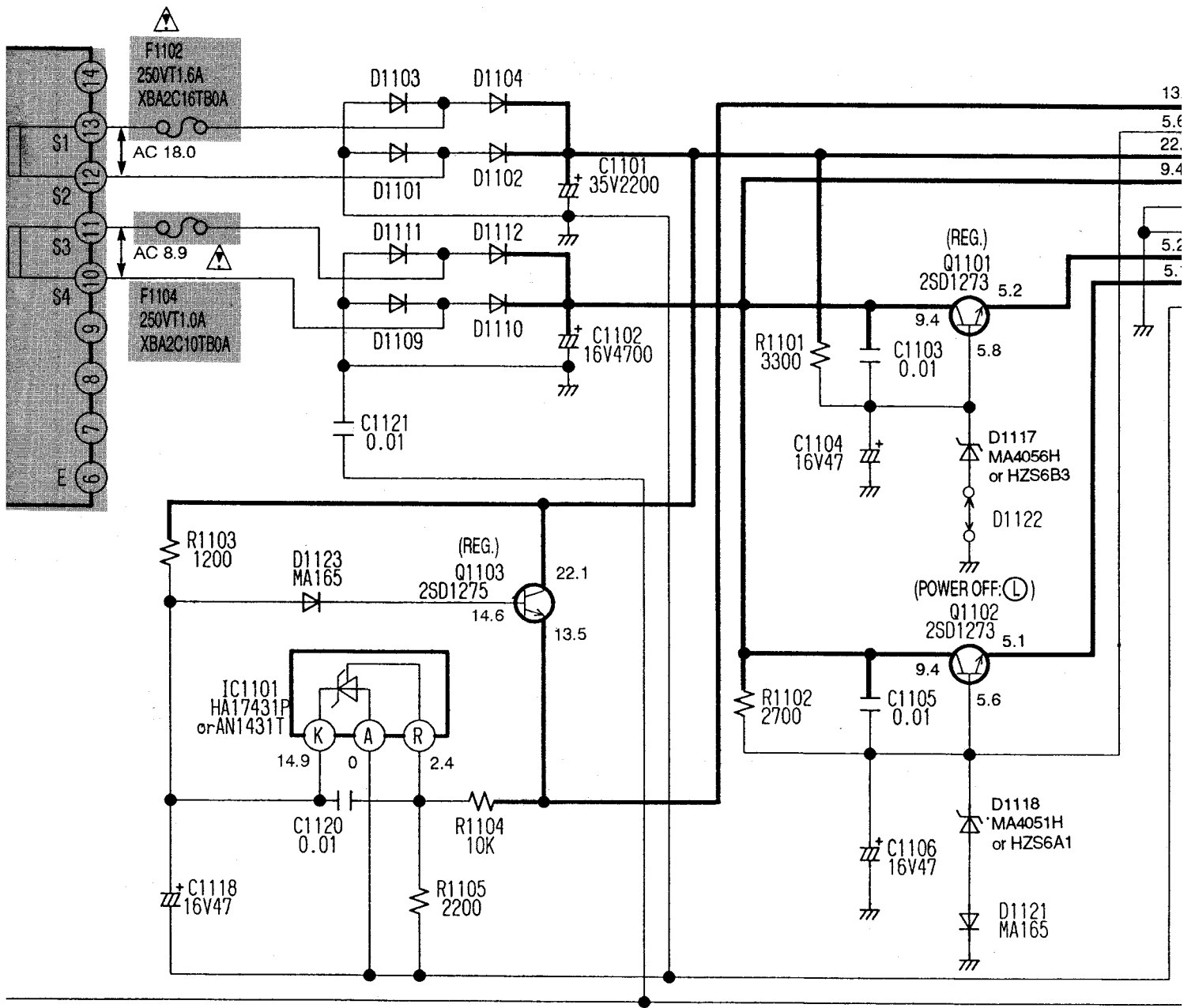

EMENT MODE OF THE DC VOLTAGE ON THIS DIAGRAM IS STOP MODE.

**NOTICE:**  
 FIED WITH THE MARK  HAVE  
 TERISTICS FOR SAFETY.  
 Y OF THESE COMPONENTS,  
 TYPE.

NOTE 1. WHEN MEASURE THE VOLTAGE ON THE POWER CIRCUIT, SET  
 THE GND TERMINAL OF MEASURING POINT AS FOLLOWS.

SECONDARY SIDE ..... P1101-5Pin

NOTE 2. THE DC VOLTAGE INDICATED IN PRIMART SIDE IS SHOWN THE VOLTAGE WH

3

4

5



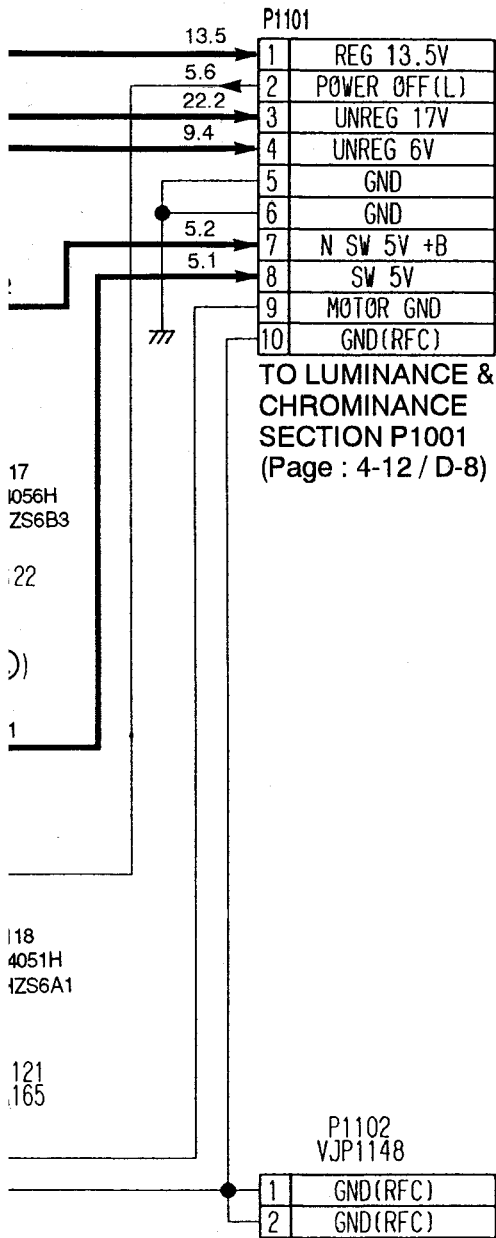

SET

THE VOLTAGE WHEN INPUT AC IS 220V.

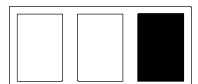

4-3.SYSTEM CONTROL & SERVO SECTION IN MAIN SCHEMATIC DIAGRAM

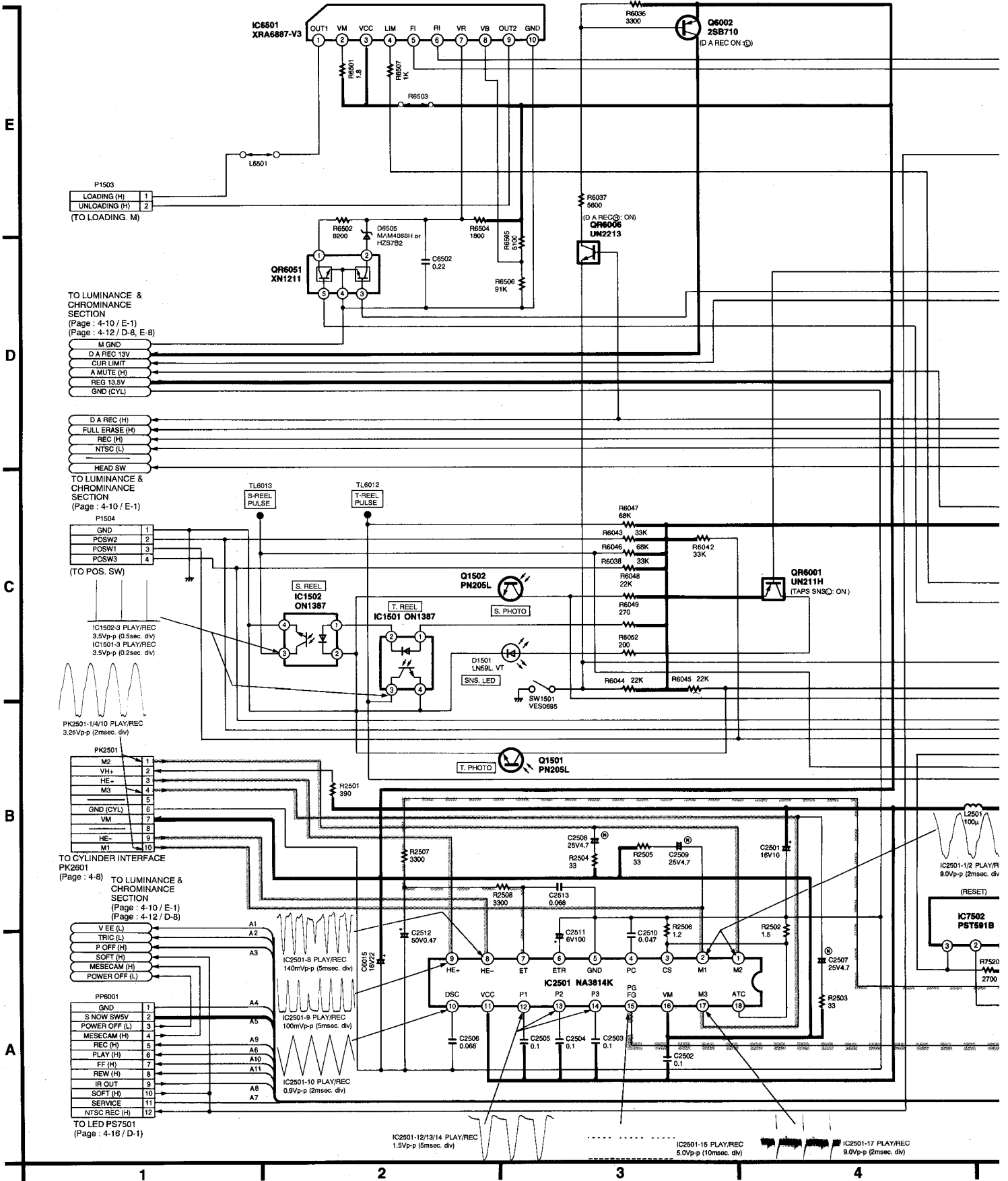

P1503

LOADING (H)	1
UNLOADING (H)	2

(TO LOADING. M)

TO LUMINANCE & CHROMINANCE SECTION  
(Page : 4-10 / E-1)  
(Page : 4-12 / D-8, E-8)

M GND	
D A REC 13V	
CUR LIMIT	
A MUTE (H)	
REG 13.5V	
GND (CYL)	

TO LUMINANCE & CHROMINANCE SECTION  
(Page : 4-10 / E-1)

D A REC (H)	
FULL ERASE (H)	
REC (H)	
NTSC (L)	
HEAD SW	

P1504

GND	1
POSW2	2
POSW1	3
POSW3	4

(TO POS. SW)

PK2501

M2	1
VH+	2
HE+	3
M3	4
GND (CYL)	5
VM	6
HE-	7
M1	8
M2	9
M1	10

TO CYLINDER INTERFACE  
PK2801  
(Page : 4-8)

TO LUMINANCE & CHROMINANCE SECTION  
(Page : 4-10 / E-1)  
(Page : 4-12 / D-8)

V EE (L)	A1
TRIC (L)	A2
P OFF (H)	A3
SOFT (H)	A3
MESECAM (H)	A3
POWER OFF (L)	A3

PP6001

GND	1
S NOW SW5V	2
POWER OFF (L)	3
MESECAM (H)	4
REC (H)	5
PLAY (H)	6
FF (H)	7
REW (H)	8
IR OUT	9
SOFT (H)	10
SERVICE	11
NTSC REC (H)	12

TO LED PS7501  
(Page : 4-16 / D-1)

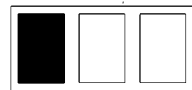

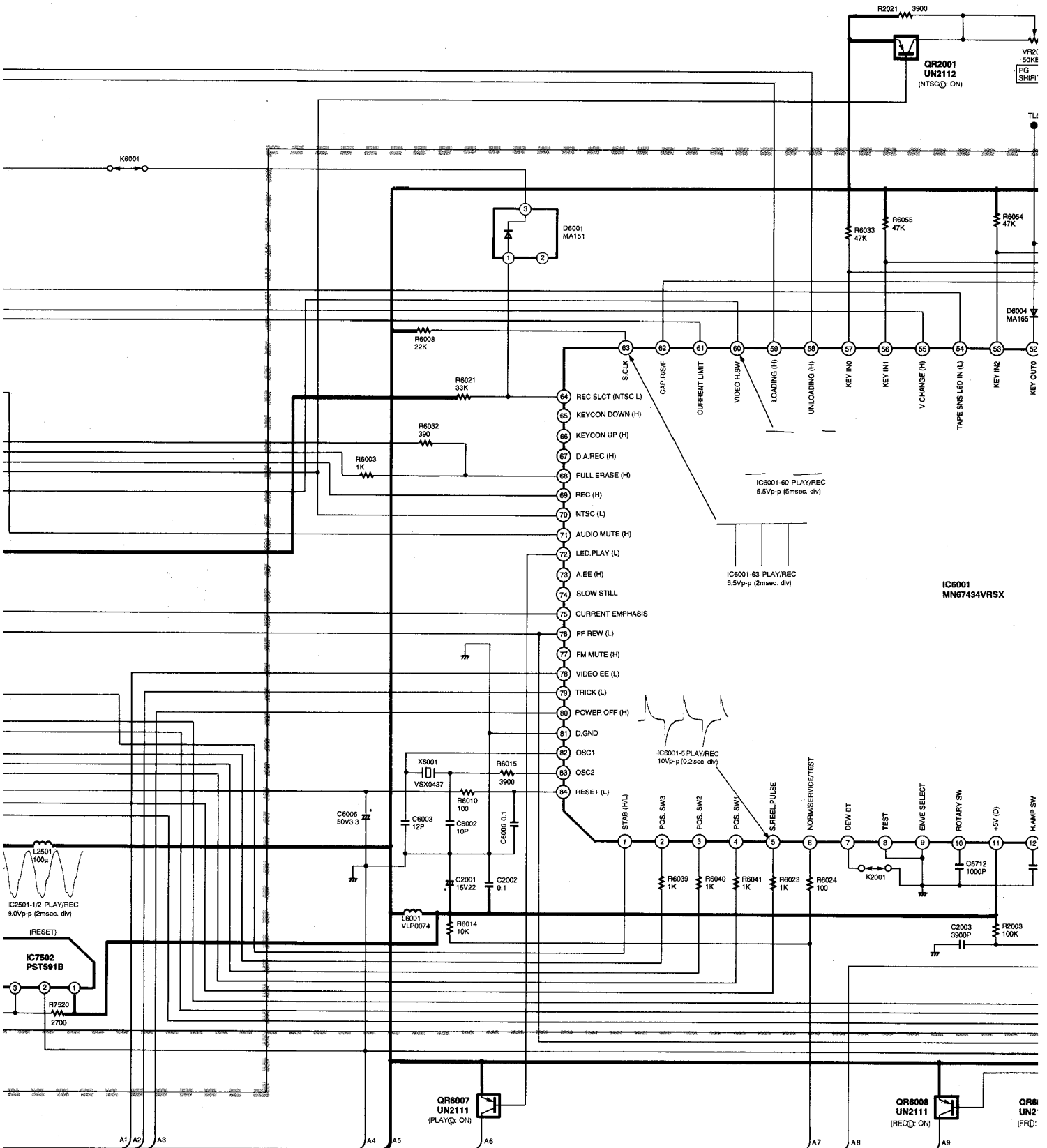

5

6

7

8

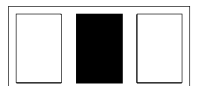

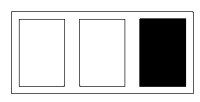
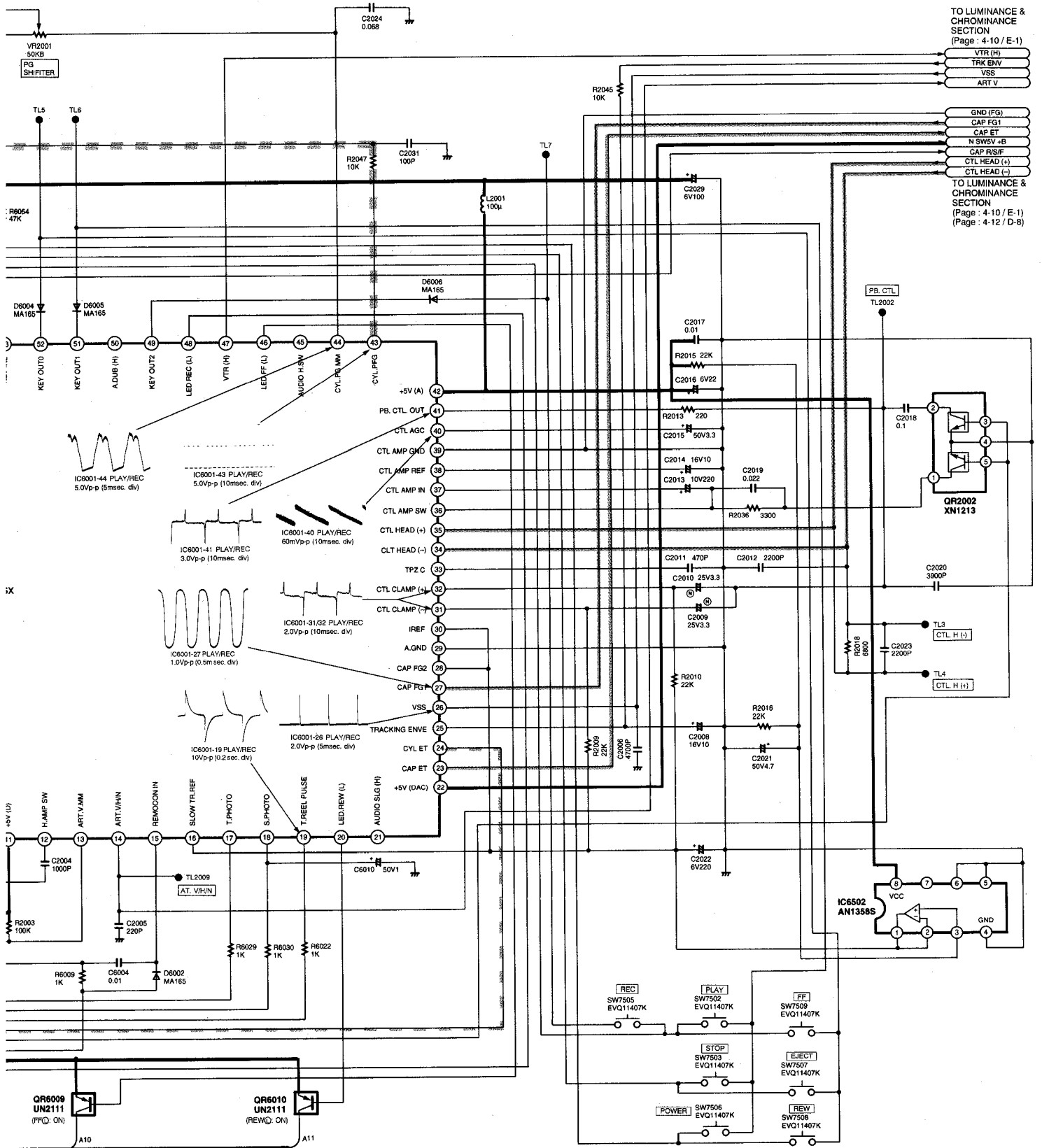

## ■ CYLINDER INTERFACE SCHEMATIC DIAGRAM

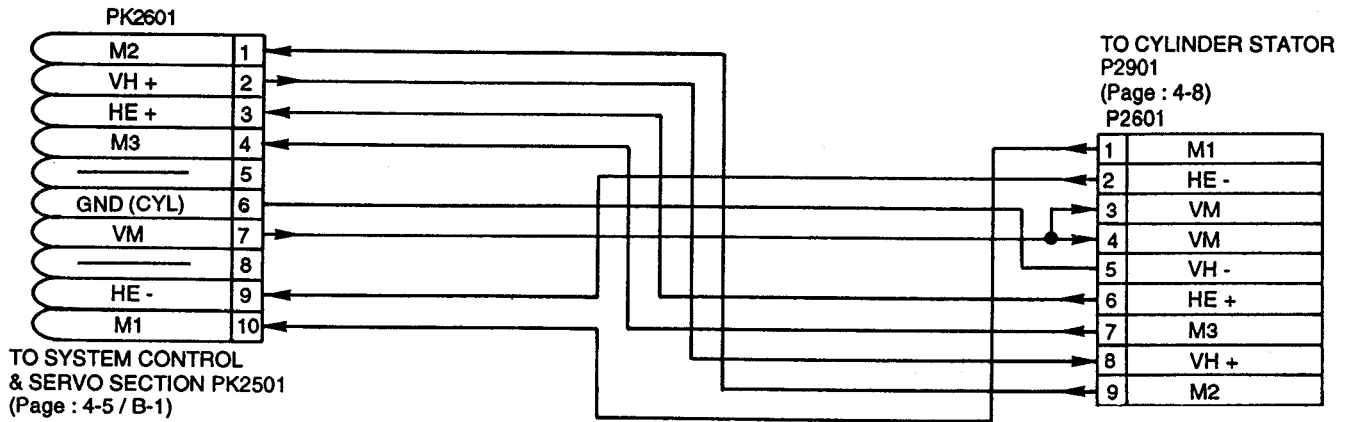

## ■ CYLINDER STATOR SCHEMATIC DIAGRAM

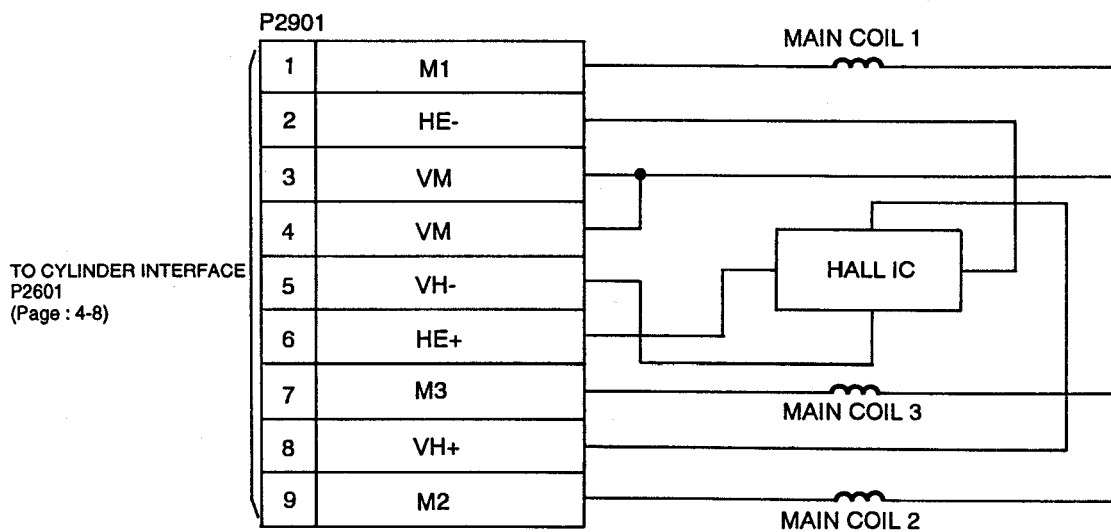

## SYSTEM CONTROL & SERVO TRANSISTORS DC VOLTAGE CHART (SP MODE)

REF.NO.	Q1501			Q1502			Q6002											
MODE	+	-		+	-		E	C	B									
STOP	5.1	0		5.1	0		13.4	0.1	13.4									
PLAY	5.1	0		5.1	0		13.4	0.1	13.4									
REC	5.1	0		5.1	0		13.4	13.3	12.6									
F.F	5.1	0		5.1	0		13.4	0.1	13.4									
REW	5.1	0		5.1	0		13.4	0.1	13.4									
REF.NO.	QR2001			QR2002					QR6001			QR6006			QR6007			
MODE	E	C	B	1	2	3	4	5		E	C	B	E	C	B	E	C	B
STOP	5.2	4.9	5.2	0	0	5.1	0	5.1		5.2	-0.9	5.2	4.2	13.4	0	5.2	-1.3	5.2
PLAY	5.2	4.9	5.2	0	0	5.1	0	5.1		5.2	5.1	0	4.2	13.4	0	5.2	5.2	0
REC	5.2	4.9	5.2	0	0	5.1	0	5.1		5.2	5.1	0	0	0	5.1	5.2	-1.3	5.2
F.F	5.2	4.9	5.2	0	2.6	0	0	0		5.2	5.1	0	0	13.4	0	5.2	-1.3	5.2
REW	5.2	4.9	5.2	0	2.6	0	0	0		5.2	5.1	0	0	13.4	0	5.2	-1.3	5.2
REF.NO.	QR6008			QR6009			QR6010			QR6501								
MODE	E	C	B	E	C	B	E	C	B	1	2	3	4	5				
STOP	5.2	-	5.2	5.2	-	5.2	5.2	0.1	5.2	0	0	5.1	0	5.1				
PLAY	5.2	-	5.2	5.2	-	5.2	5.2	0.1	5.2	0	0	5.1	0	5.1				
REC	5.2	5.1	0	5.2	-	5.2	5.2	-0.9	5.2	0	0	5.1	0	5.1				
F.F	5.2	-	5.2	5.2	5.1	0	5.2	0.1	5.2	13.4	7.6	0	0	0				
REW	5.2	-	5.2	5.2	-	5.2	5.2	5.1	0	13.4	7.6	0	0	0				

# 4-4.LUMINANCE & CHROMINANCE SECTION IN MAIN SCHEMATIC DIAGRAM

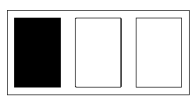
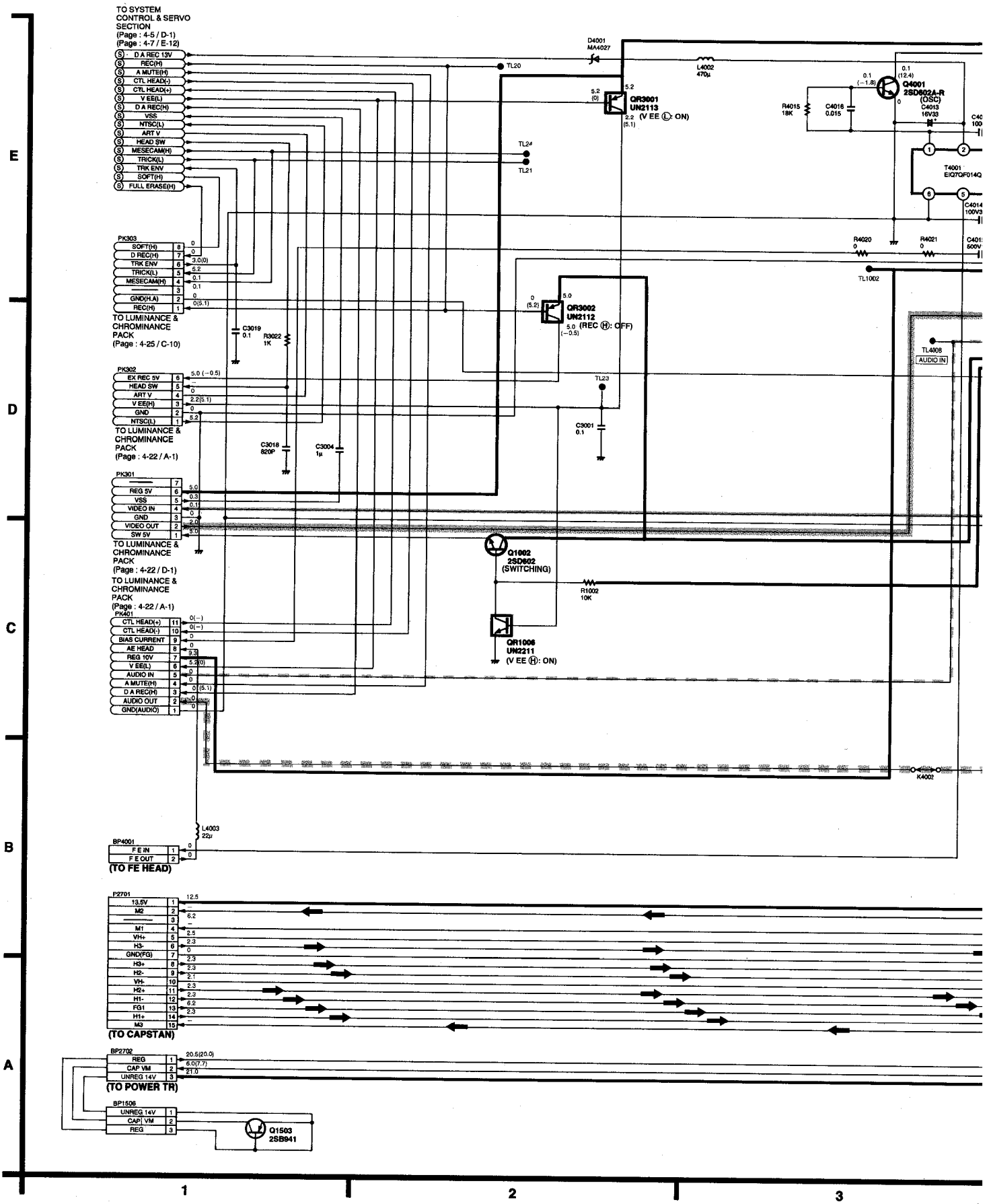



← CAPSTAN SERVO PHASE LOOP

VIDEO MAIN

VIDEO MAIN

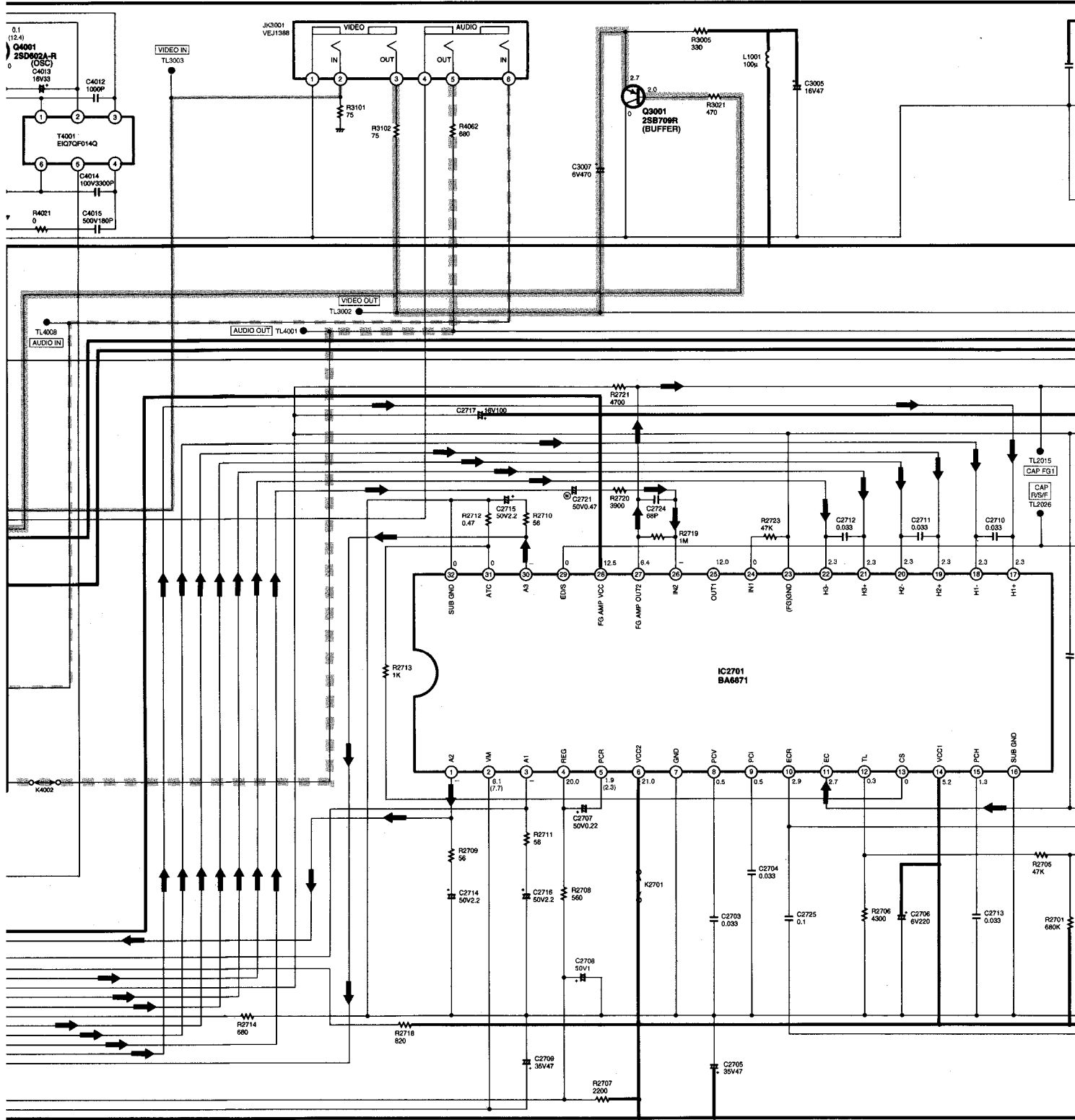

4

5

6



O MAIN SIGNAL PATH IN REC MODE  
 O MAIN SIGNAL PATH IN PLAYBACK MODE

AUDIO MAIN SIGNAL PATH IN REC MODE  
 AUDIO MAIN SIGNAL PATH IN PLAYBACK MODE

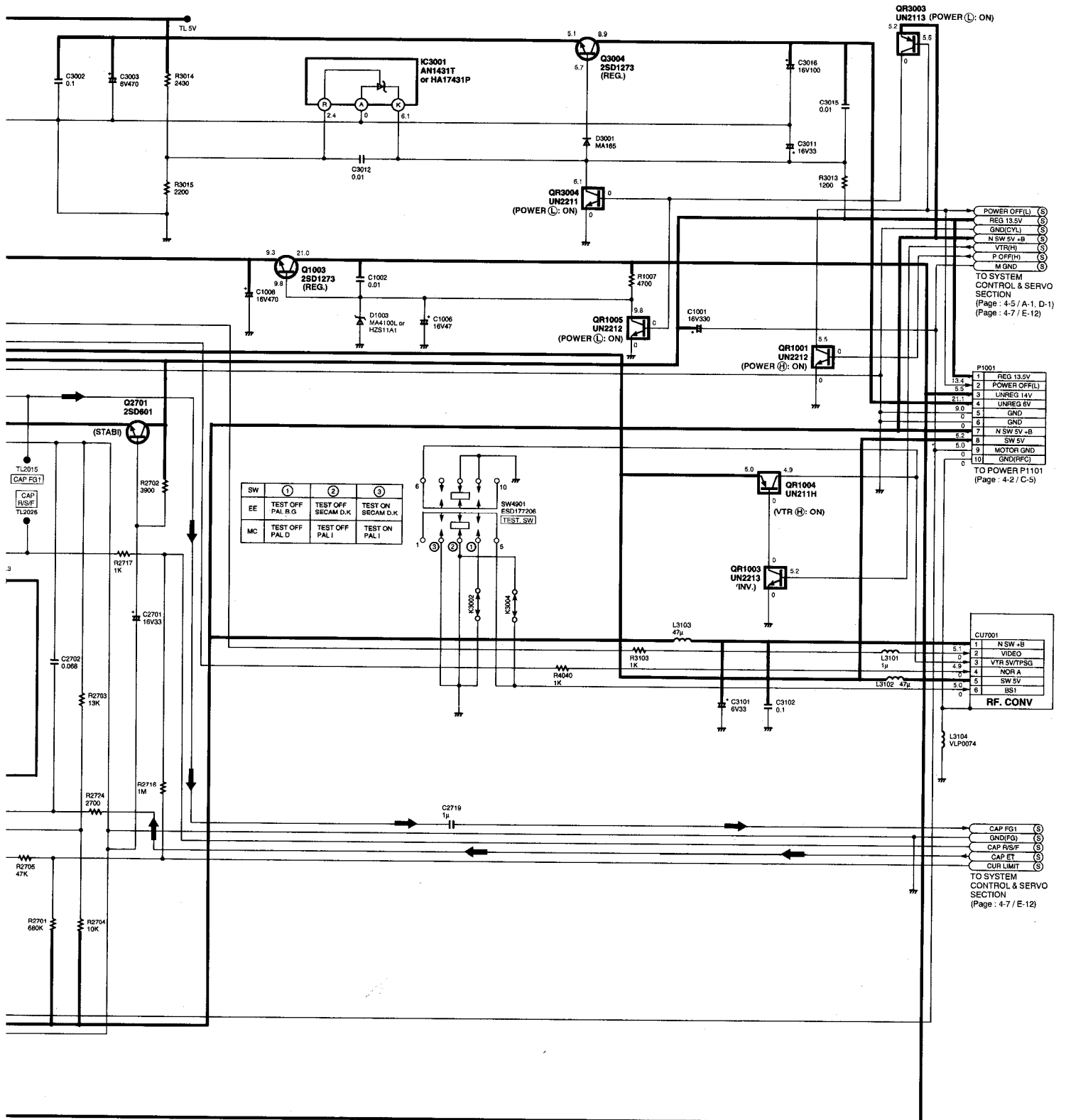

NOTE: DO NOT USE ANY PART NUMBER SHOWN ON THIS SCHEMATIC DIAGRAM FOR ORDERING. WHEN YOU ORDER A PART, PLEASE REFER TO PARTS LIST.

NOTE: THE MEASUREMENT MODE OF THE DC VOLTAGE IN THE BRACKETS( ) ON THIS DIAGRAM IS RECORD MODE WITH PAL COLOUR SIGNAL. (SP MODE)  
 THE MEASUREMENT MODE OF THE DC VOLTAGE OUT OF THE BRACKETS ON THIS DIAGRAM IS PLAYBACK MODE WITH PAL COLOUR SIGNAL. (SP MODE)

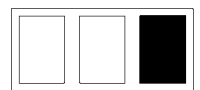

# 4-6.LED SCHEMATIC DIAGRAM

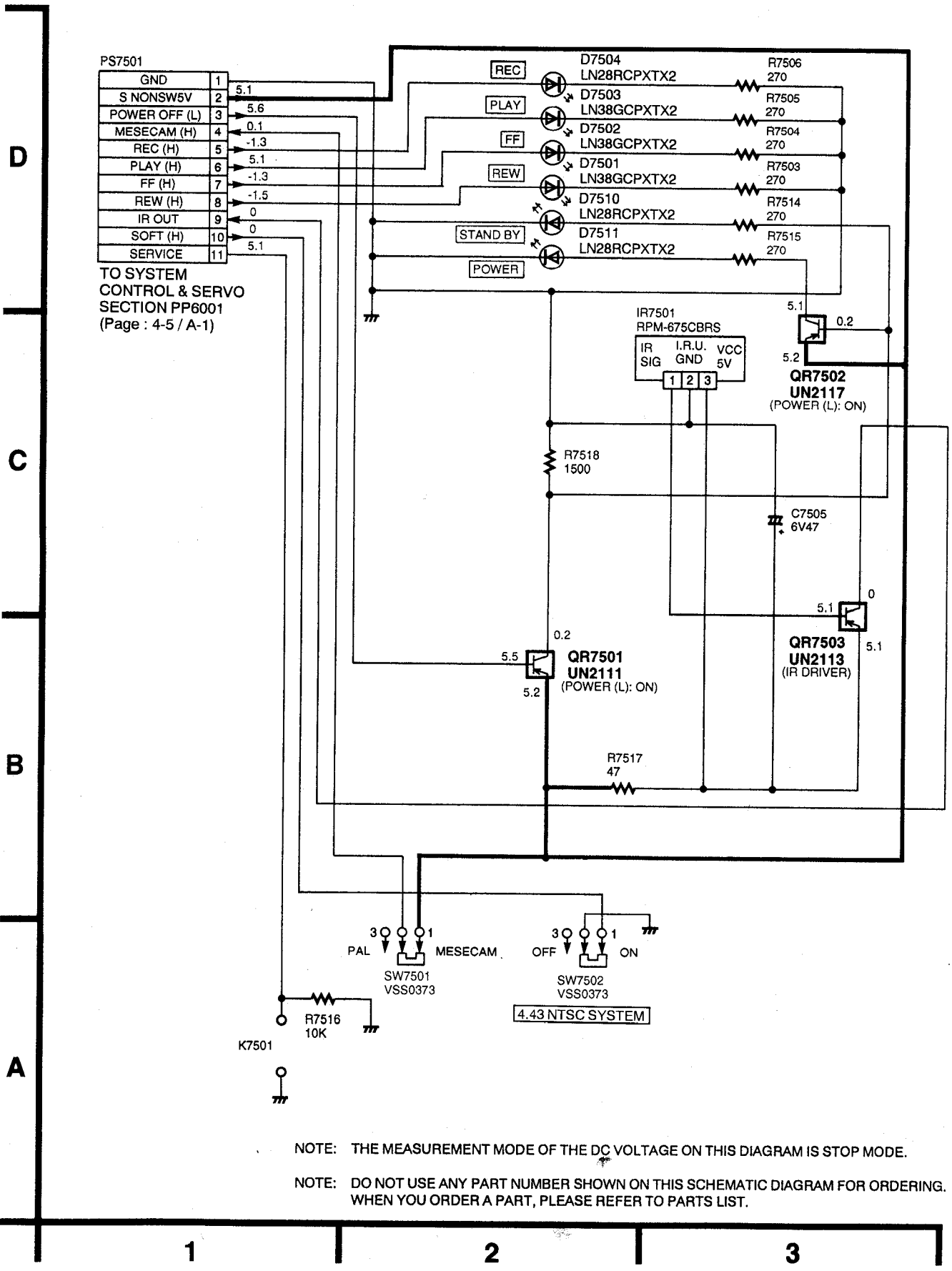

NOTE: THE MEASUREMENT MODE OF THE DC VOLTAGE ON THIS DIAGRAM IS STOP MODE.  
 NOTE: DO NOT USE ANY PART NUMBER SHOWN ON THIS SCHEMATIC DIAGRAM FOR ORDERING. WHEN YOU ORDER A PART, PLEASE REFER TO PARTS LIST.

# 4-8.HEAD AMP SCHEMATIC DIAGRAM

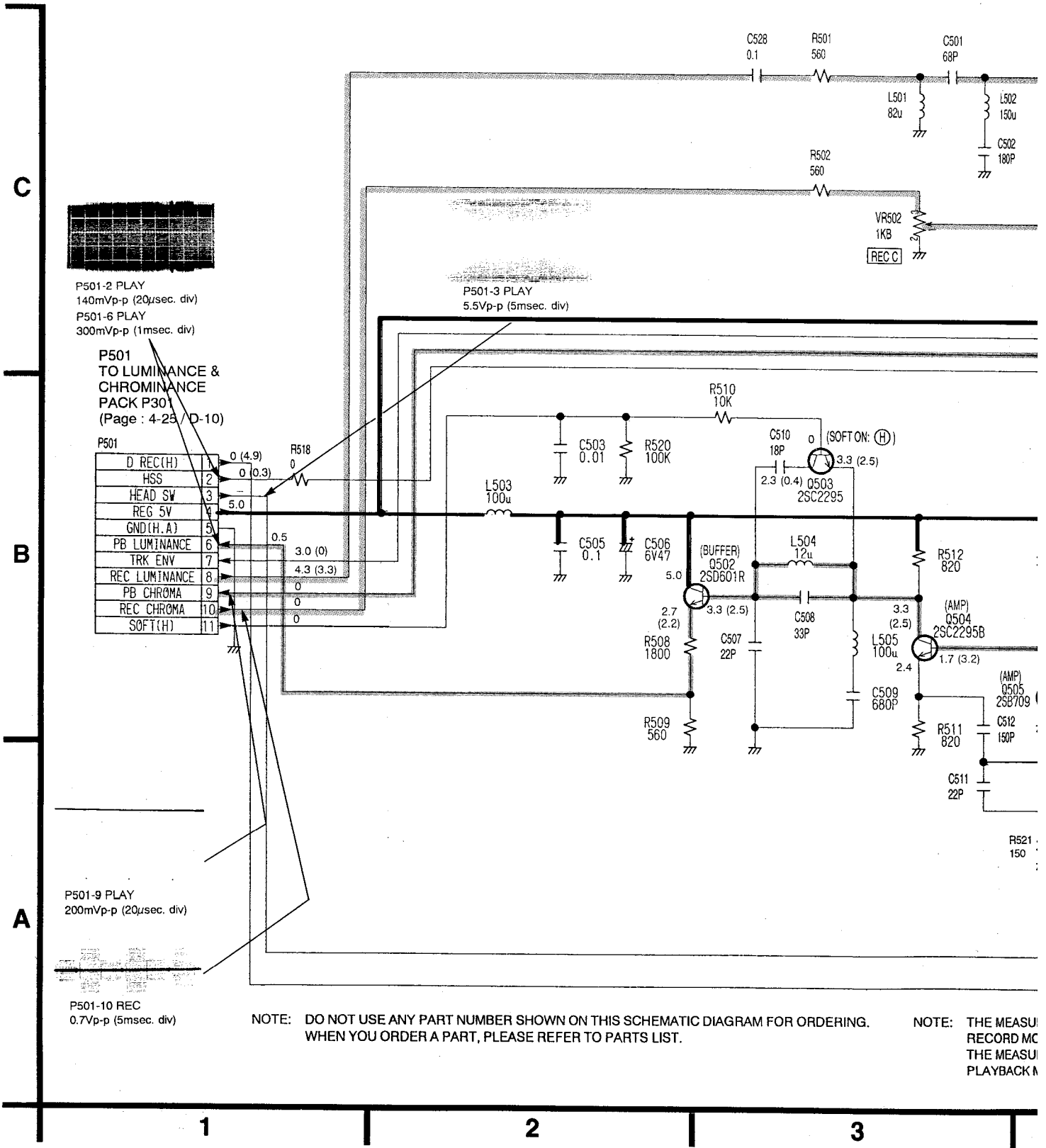

----- VIDEO MAIN SIGNAL PATH IN PLAYBACK MODE  
 ----- VIDEO MAIN SIGNAL PATH IN REC MODE

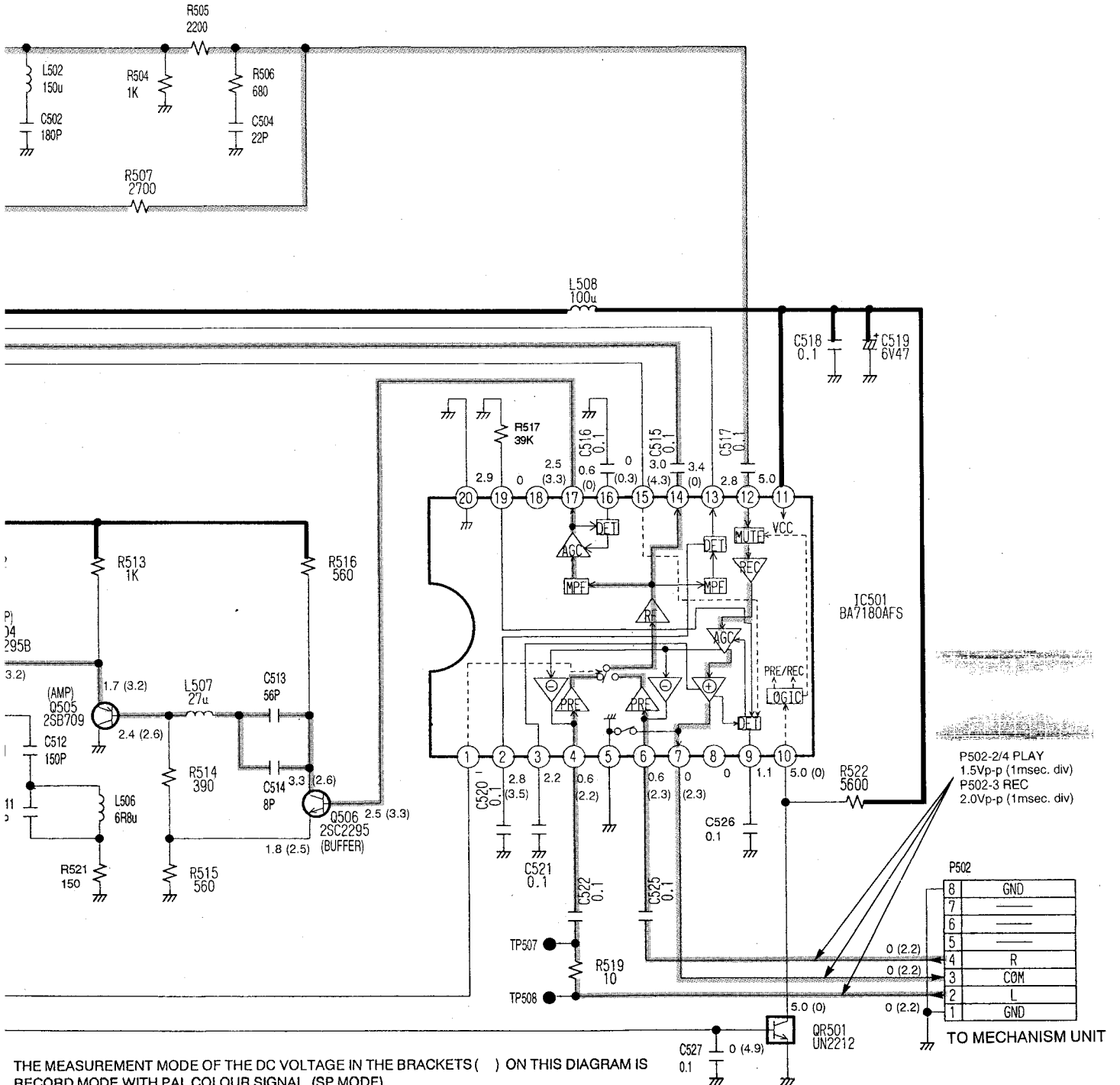

THE MEASUREMENT MODE OF THE DC VOLTAGE IN THE BRACKETS ( ) ON THIS DIAGRAM IS RECORD MODE WITH PAL COLOUR SIGNAL. (SP MODE)  
 THE MEASUREMENT MODE OF THE DC VOLTAGE OUT OF THE BRACKETS ON THIS DIAGRAM IS PLAYBACK MODE WITH PAL COLOUR SIGNAL. (SP MODE)

4

5

6



# 4-10.LUMINANCE & CHROMINANCE PACK SCHEMATIC DIAGRAM

NOTE: THE MEASUREMENT MODE OF THE DC VOLTAGE IN THE BRACKETS ( ) ON THIS DIAGRAM IS RECORD MODE WITH PAL COLOUR SIGNAL. (SP MODE)  
THE MEASUREMENT MODE OF THE DC VOLTAGE OUT OF THE BRACKETS ON THIS DIAGRAM IS PLAYBACK MODE WITH PAL COLOUR SIGNAL. (SP MODE)

TO LUMINANCE & CHROMINANCE SECTION  
(Page : 4-10 / C-1)

PK301		
SW 5V	1	5.0
VIDEO OUT	2	2.0
GND	3	0
VIDEO IN	4	0.1
VSS	5	0.3
REG 5V	6	5.0

P401		
AE HEAD	1	0
AUDIO GND	2	0
A HEAD (R)	3	0
A HEAD (W)	4	0
CTL HEAD (-)	5	0(-)
CTL HEAD (+)	6	0(-)

TO AC HEAD

IC401-8 PLAY  
0.5Vp-p (0.2msec. div)

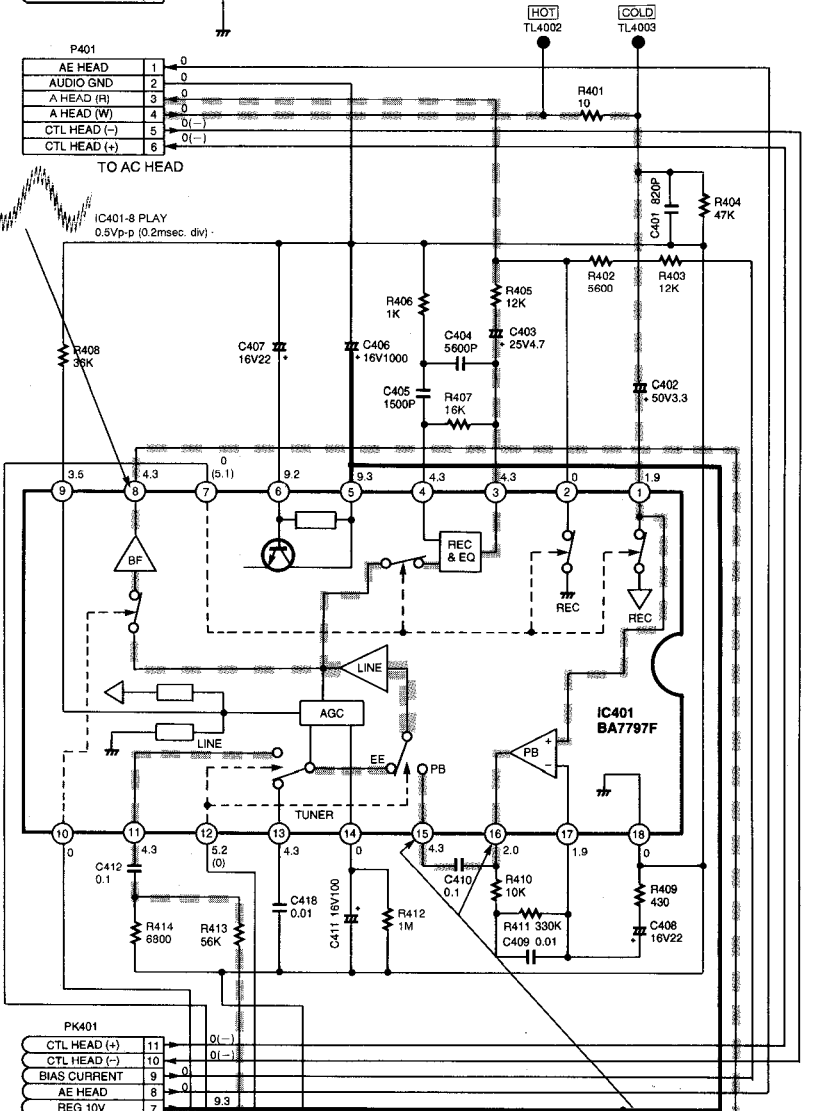

PK401		
CTL HEAD (+)	11	0(-)
CTL HEAD (-)	10	0(-)
BIAS CURRENT	9	0
AE HEAD	8	0
REG 10V	7	9.3
V EE (L)	6	5.2(0)
AUDIO IN	5	0
A MUTE (H)	4	0
D A REC (H)	3	0
AUDIO OUT	2	0(5.1)
GND (AUDIO)	1	0

TO LUMINANCE & CHROMINANCE SECTION  
(Page : 4-10 / C-1)

PK302		
NTSC(L)	1	5.2
GND	2	0
V EE(H)	3	5.1/2.2
ART V	4	0
HEAD SW	5	0
EX. REC 5V	6	5.0 (-0.5)

TO LUMINANCE & CHROMINANCE SECTION  
(Page : 4-10 / D-1)

(BUFFER)  
Q301  
2SD601

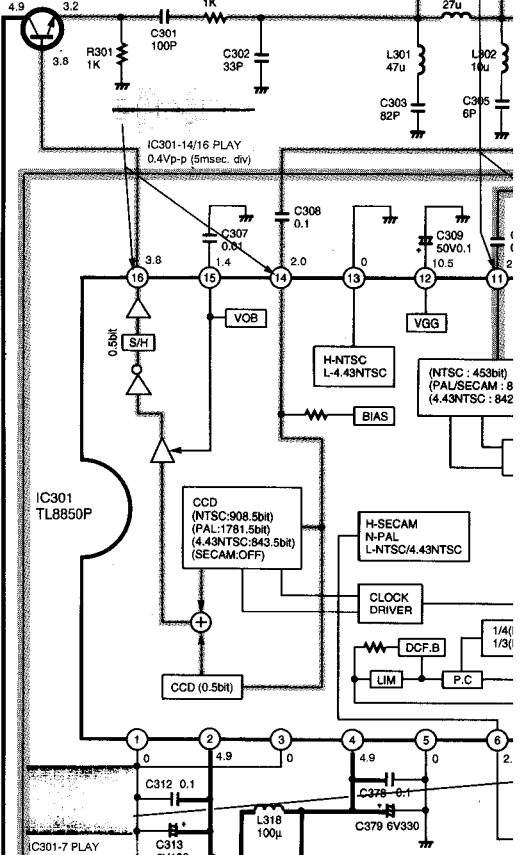

(BUFFER)  
Q303  
2SC2295

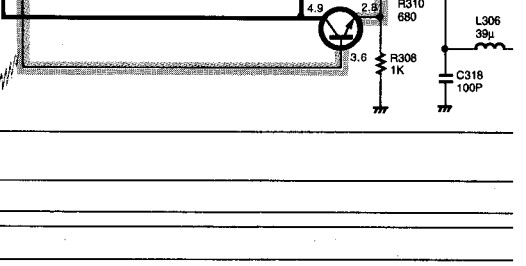

NOTE: DO NOT USE ANY PART NUMBER SHOWN ON THIS SCHEMATIC DIAGRAM FOR ORDERING. WHEN YOU ORDER A PART, PLEASE REFER TO PARTS LIST.

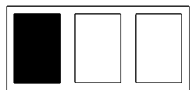

AUDIO MAIN SIGNAL PATH IN REC MODE

AUDIO MAIN SIGNAL PATH IN PLAYBACK MODE

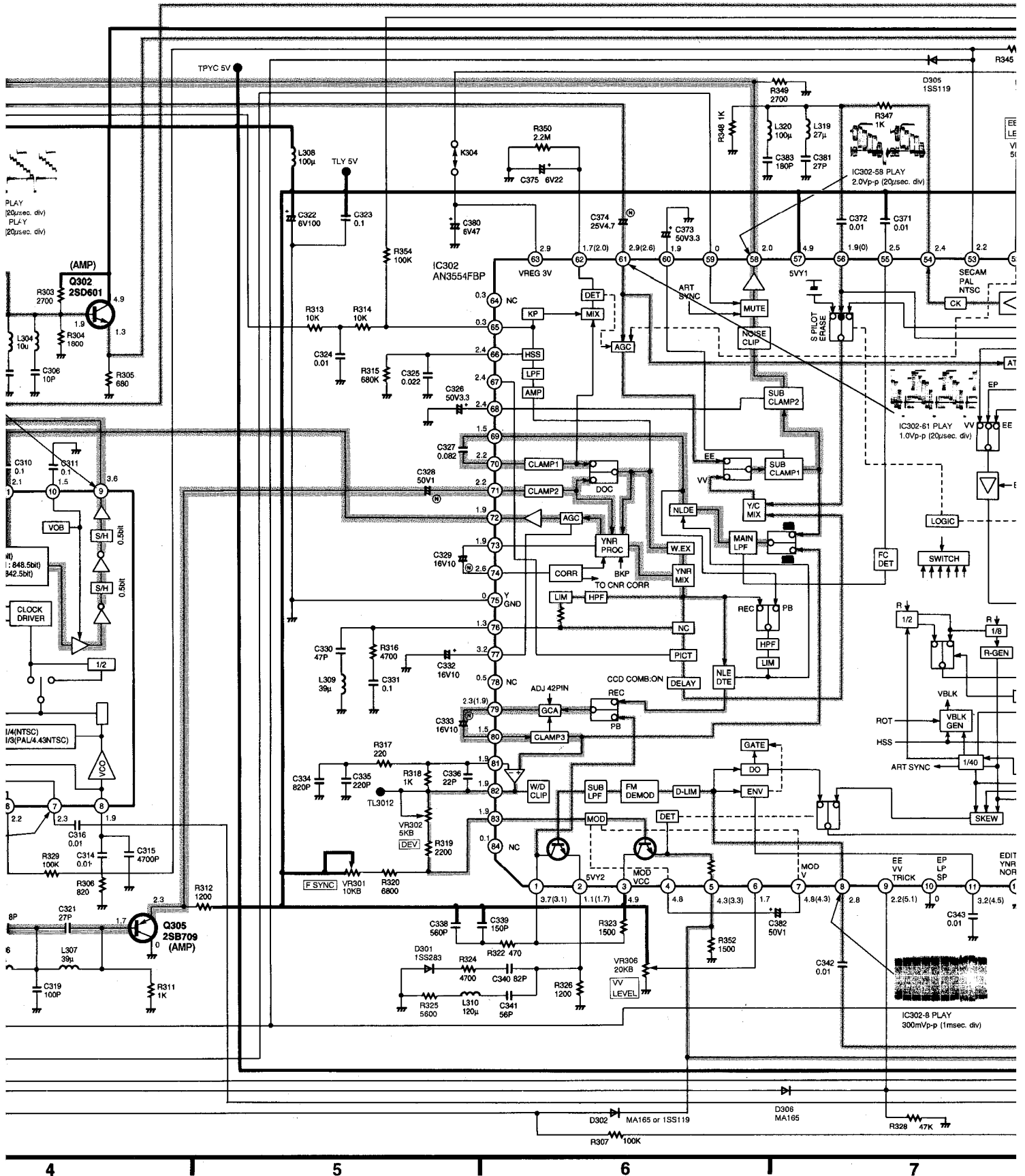

VIDEO MAIN SIGNAL PATH IN REC MODE

VIDEO MAIN SIGNAL PATH IN PLAYBACK MODE

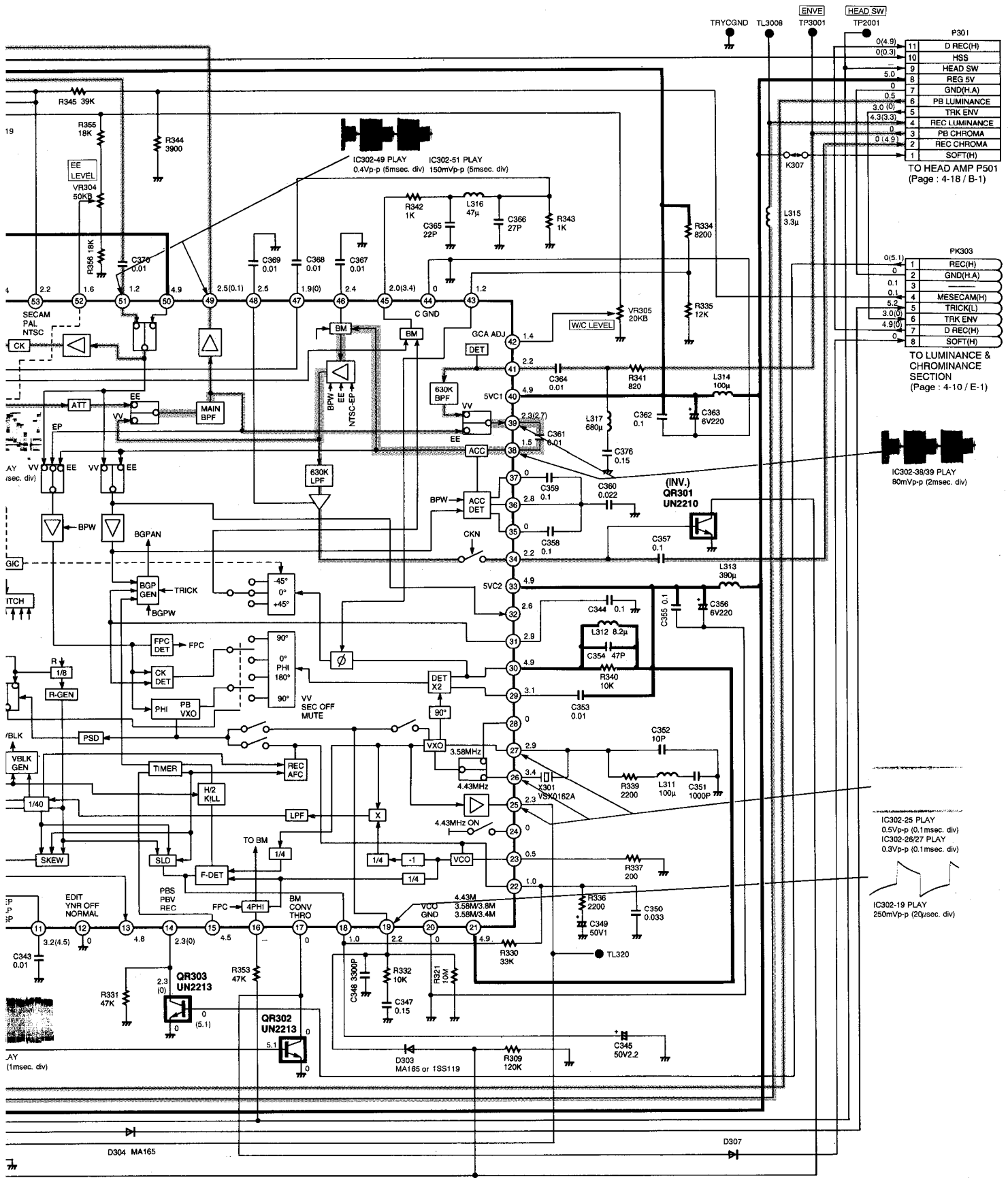

P301

11	D REC(H)
10	HSS
9	HEAD SW
8	REG SV
7	GND(H,A)
6	PB LUMINANCE
5	TRK ENV
4	REC LUMINANCE
3	PB CHROMA
2	REC CHROMA
1	SOFT(H)

TO HEAD AMP P501  
(Page: 4-18 / B-1)

PK303

1	REC(H)
2	GND(H,A)
3	0
4	0.1
5	MESECAM(H)
6	TRICK(L)
7	TRK ENV
8	D REC(H)

TO LUMINANCE & CHROMINANCE SECTION  
(Page: 4-10 / E-1)

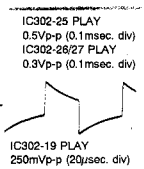

8

9

10

